



INSTALLATION MANUAL

HEAT-RECOVERY
VENTILATION UNIT,
MCFA SERIES

CONTENTS

I. INTRODUCTION AND OVERVIEW	3
1.1. SAFETY PRECAUTIONS	3
1.2. DELIVERY PACKAGE	4
II. UNIT DESCRIPTION	5
2.1. OPERATION PRINCIPLE AND FUNCTIONS	5
2.2. OUTLINE DRAWINGS	5
2.3. SPECIFICATIONS	6
III. INSTALLATION	7
3.1. LOCATION	7
3.2. WALL INSTALLATION	7
3.3. AIR DUCTS	7
3.4. WIRING CONNECTION	8
3.5. CONDENSATE DRAINAGE	11
IV. PRE-START SETTINGS	12
4.1. INSPECTION BEFORE OPERATION	12
4.2. DEFAULT FACTORY SETTINGS	12
4.3. CONTROL PANELS	12
V. TROUBLESHOOTING	15
VI. ACCESSORIES	15

I. INTRODUCTION AND OVERVIEW

Dear users!

Thank you for choosing our unit. We do our best to ensure efficient and trouble-free commissioning, as well as ensure the unit operation meets your expectations regarding the corresponding air exchange process.

Air heat recovery unit is a unit that requires, first of all, correct selection, assembly, configuration, and maintenance. Improper performance of the above steps may result in poor capacity and even eventual unit damage.

1.1. SAFETY PRECAUTIONS

Please read the following safety instructions before installing the unit. Follow all the instructions to avoid injury, as well as equipment or property damage.

WARNING!

Risk of injury or equipment damage.

1.1.1. Installation

- Installation and maintenance of the unit must be performed by a qualified technician. The user may not install the equipment on their own, as this may be dangerous.
- The unit must be connected to a power source and earthed by a qualified electrician.
- Consider the unit weight and size when relocating and installing the unit.
- Install the unit following the installation instructions.
- The unit must be installed in a dry room with no flammable gas leakages.
- Ventilation openings of the outdoor unit must be covered with a bird net or similar means. If they are obstructed with nests or obstacles, clear them and remove the obstacles, otherwise the incoming air flow will be reduced.

1.1.2. Operation

- Children and persons with limited physical and intellectual/mental capabilities or lack of experience and knowledge may only use this unit under supervision or direction of a person responsible for their safety.
- The unit must be powered with the rated voltage. Improper voltage may result in fire or electric shock.
- Replace the filter at the recommended/required intervals.
- Do not use corrosive substances or solvents to clean the unit.
- Do not touch the equipment with wet hands.

1.1.3. Технічне обслуговування

- If any abnormal noise, odour or smoke is noticed, power the unit off and call in an installer.
- Power the unit off before maintenance.
- Do not modify the unit. The parts may only be replaced with original spare parts provided by the manufacturer; the replacement must be performed by a qualified technician.

1.2. DELIVERY PACKAGE

The unit comes with the components listed below. Check them once you open the box. If any components are damaged or missing, contact the supplier immediately.

	<p>Heat-recovery ventilation unit, 1 pce. Check whether the model and the label data are correct.</p>
	<p>Mounting bracket, 1 pce.</p>
	<p>Condensate drain pipe connector (with an O-ring), 1 pce.</p>
	<p>Condensate drain plug (with an O-ring), 1 pce.</p>
	<p>Manual, 1 pce.</p>

II. UNIT DESCRIPTION

2.1. OPERATION PRINCIPLE AND FUNCTIONS

The unit is designed to provide mechanical supply-and-exhaust ventilation combined with heat recovery. It is equipped with a heat exchanger, filters, EC motor, etc. The unit functions are as follows:

- Fresh air purification: when outdoor air is fed into the room by the supply fan, it passes through a filter, thus becoming much cleaner.
- Energy recovery: the unit is equipped with a heat exchanger that can draw energy from the exhaust air and transfer it to the outdoor air supplied into the room. This greatly reduces the energy losses.

2.2. OUTLINE DRAWINGS

MCFA250T, MCFA350T

Units of measurement: mm

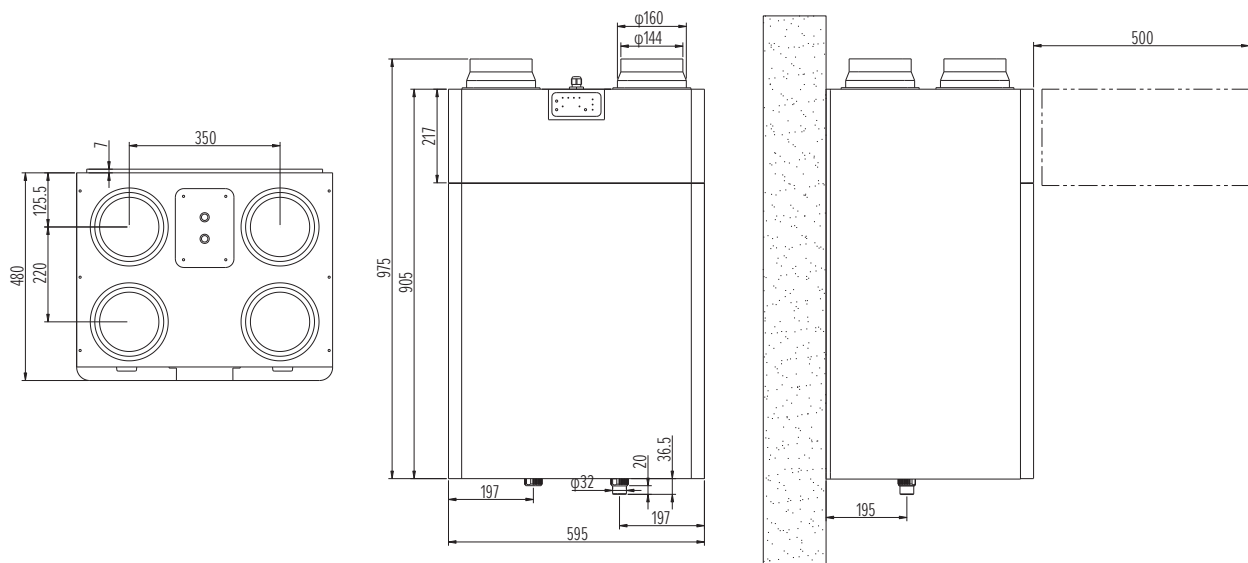

MCFA500T

Units of measurement: mm

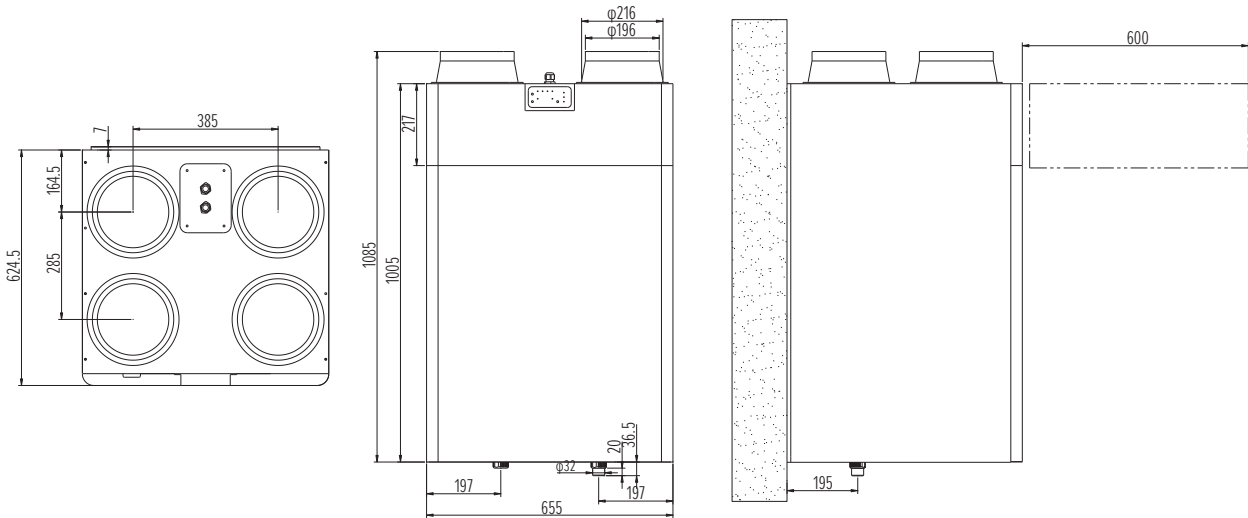

2.3. SPECIFICATIONS

Model		MCFA250T	MCFA350T	MCFA500T
Main data	Body material	Sputter-coated metal sheet		
	Internal structure	Expanded polypropylene (EPP)		
	Heat exchanger	Polystyrene		
	Fan motor	EC		
	Filter class	G4 or (optional) F7		
	Control panel	Dual-screen control, buttons + indicator light / digital light		
	Bypass	100% automatic bypass		
Operation conditions	Standard	-10 to 40°C		
	Heater-equipped	-20 to 40°C		
Pipe connection	Pipe diameter	Φ160 mm		Φ200 mm
Electrical specifications	Power supply	230 B / 50 Hz		
	Max. power	170 W	320 W	480 W
	Max. current	1,5 A	2.4A	3.2A

III. INSTALLATION

3.1. LOCATION

- All the installation works must be performed by qualified personnel. In particular, all the connection and wiring works must be performed by a qualified electrician.
- This unit is designed for installation at warehouses, in attics, or on technical floors. The installation room must be selected so that the unit will not be affected by frost, water or excessive temperatures.
- Provide working space around the unit for installation and connection of air ducts, wiring, and condensed water drainage pipelines. This will also facilitate replacement of the filters.
- Install the unit in such a position as to enable water drainage.

3.2. WALL INSTALLATION

- The unit must be installed on the wall in a vertical position.
- Hang the unit on the wall using a suspension plate (the wall must bear the weight of at least 60 kg); dimensions of the suspension plate are shown on the right.

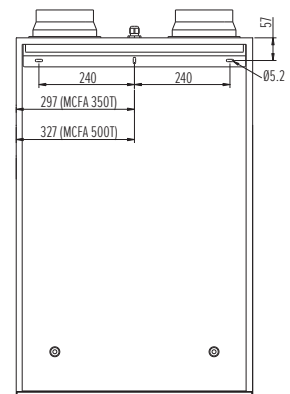

3.3. AIR DUCTS

The user can adjust positions of the inlet and outlet air ducts on the unit. To do so, first select and install the air duct, then adjust the filter position, and finally select the appropriate control program as described in the operation instructions (paragraph 4.3).

Note 1: By default, the unit comes in the configuration with right-side air duct installation.



Right-side installation (standard)



Left-side installation

In order to switch from right-side installation (factory default) to left-side installation, perform the following steps:

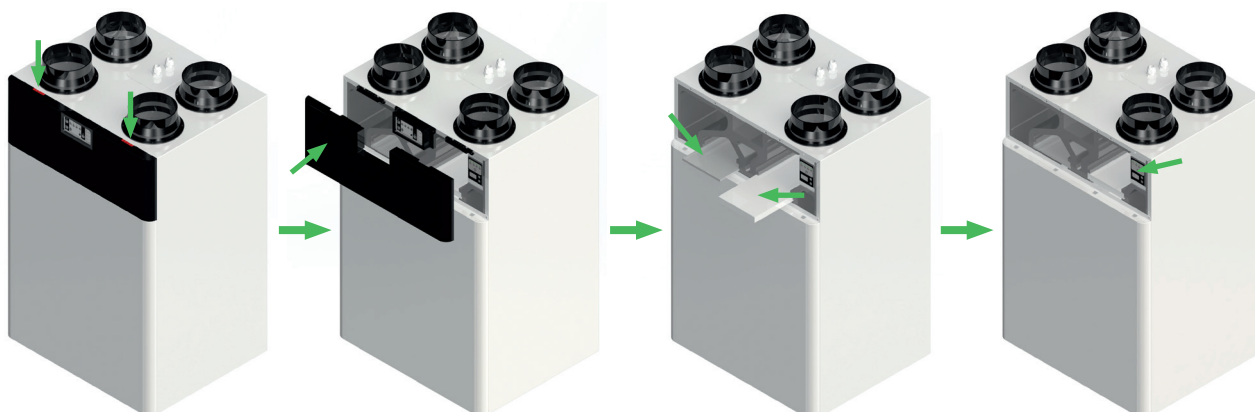

- Step 1. Press on the protective panel in the place shown to disconnect its fixture.
- Step 2. Remove the protective panel.
- Step 3. If the unit is equipped with an optional F7 filter, switch positions of the two filters as shown. Note that you can skip this step if both filters are G4.
- Step 4. Select an appropriate control program using a concealed control panel in the top right corner of the unit, following the instructions (paragraph 4.3).
- Step 5. Re-install the filter and the inspection panel.

3.4. WIRING CONNECTION

- Power wiring of this unit must be connected by a qualified electrician. The unit must be earthed.
- Use cables that meet the national standards. Cable cross-section is 3x1.5 mm².
- Power supply: 230 V / 50 Hz / 1 phase
- L (phase) = brown wire, N (neutral) = blue wire, GND (earth) = yellow-and-green wire
- The electrical circuit must be protected with a double-pole circuit breaker.

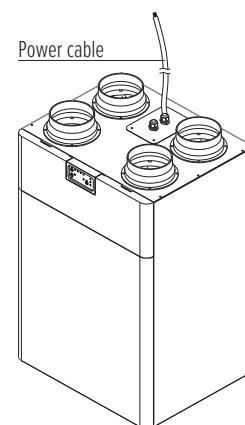

Connection of a remote controller (option)

The unit can be equipped with a remote controller which is connected using a control wire. The controller must be connected by a qualified electrician. To connect the controller, perform the following steps:

- Step 1. Power the unit off.
- Step 2. With a screwdriver, remove the screws securing the cover of the electric control box on the top of the unit.
- Step 3. Pull out the circuit board sockets to work on them
- Step 4. Open the controller enclosure.

Step 5. Connect the controller to the sockets (pulled out of the board) by connecting A, B, GND and +12 V terminals with wires.

Note. Route all the wires through the threaded connector on the cover of the electric control box and tighten the threaded connector.

Step 6. Finally, re-install the sockets with the wires connected into the board and close the electric control box.

Step 2

4 screws

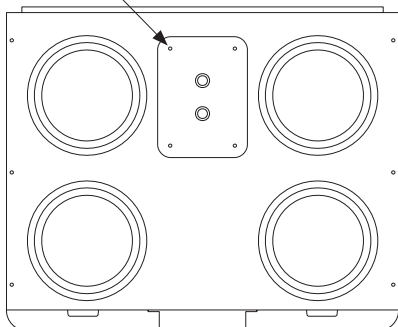

Step 3

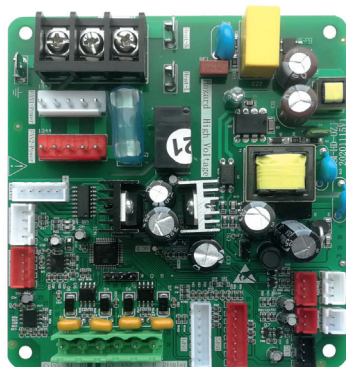

Step 4

Open the controller

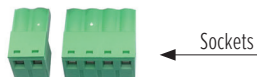
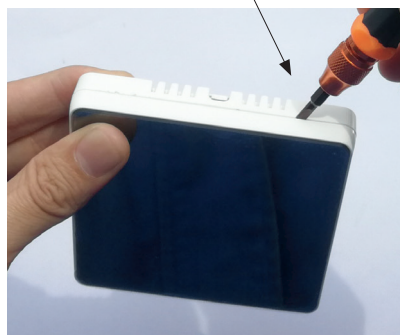

Sockets

Step 5

Back of the controller board

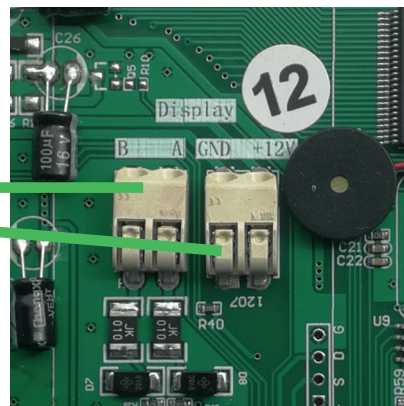
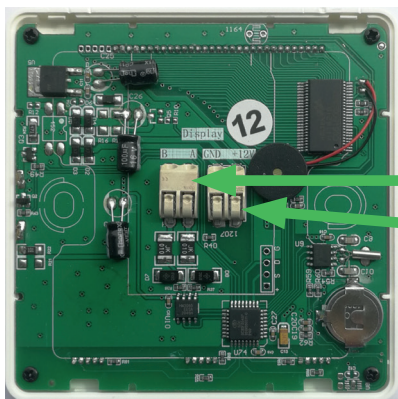

Sockets

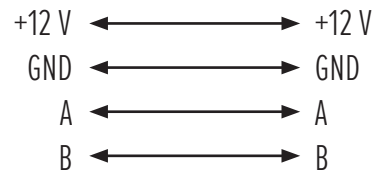
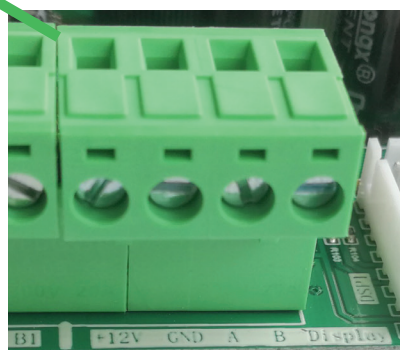

Wiring diagram

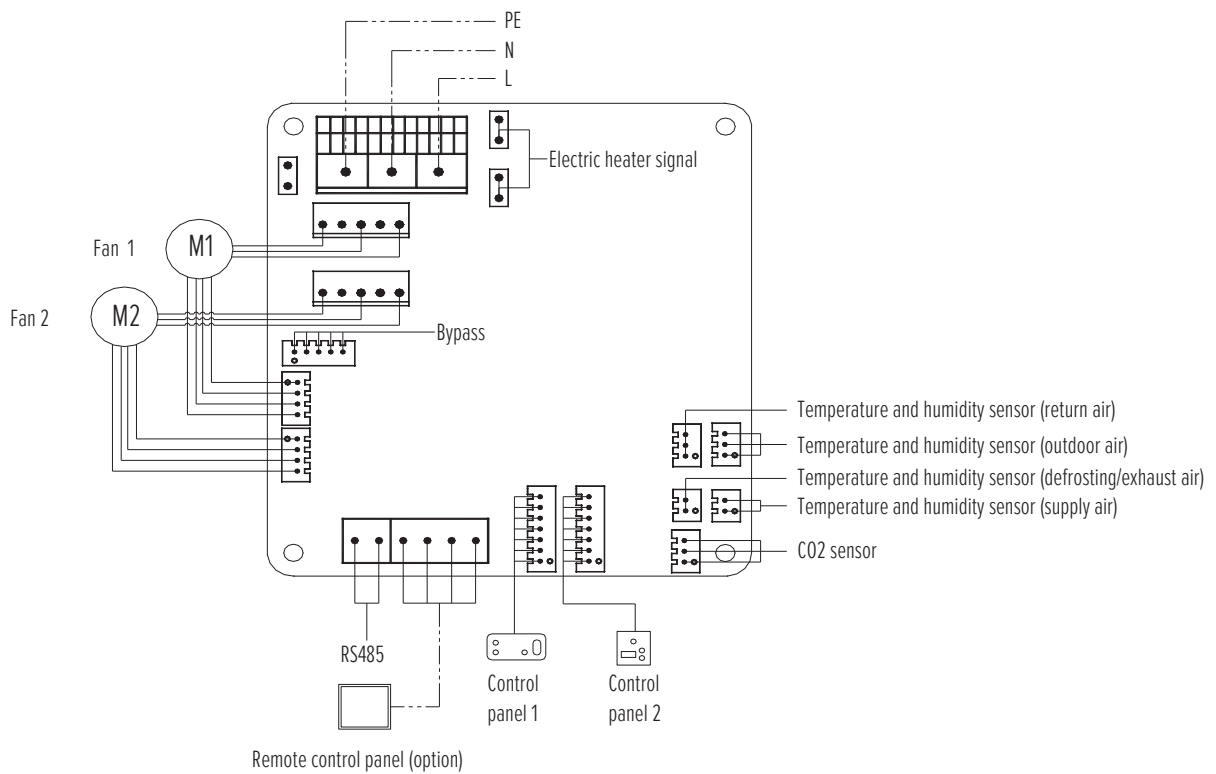

Note. This unit can be optionally equipped with a CO₂ sensor. You can also install an air duct heater (user supplied); its connection is shown on the wiring diagram.

3.5. CONDENSATE DRAINAGE

Before using the unit, connect the condensate drain pipeline as follows:

- Install the drain pipe connector and the drain pipe seal in appropriate positions, following the installation diagram.

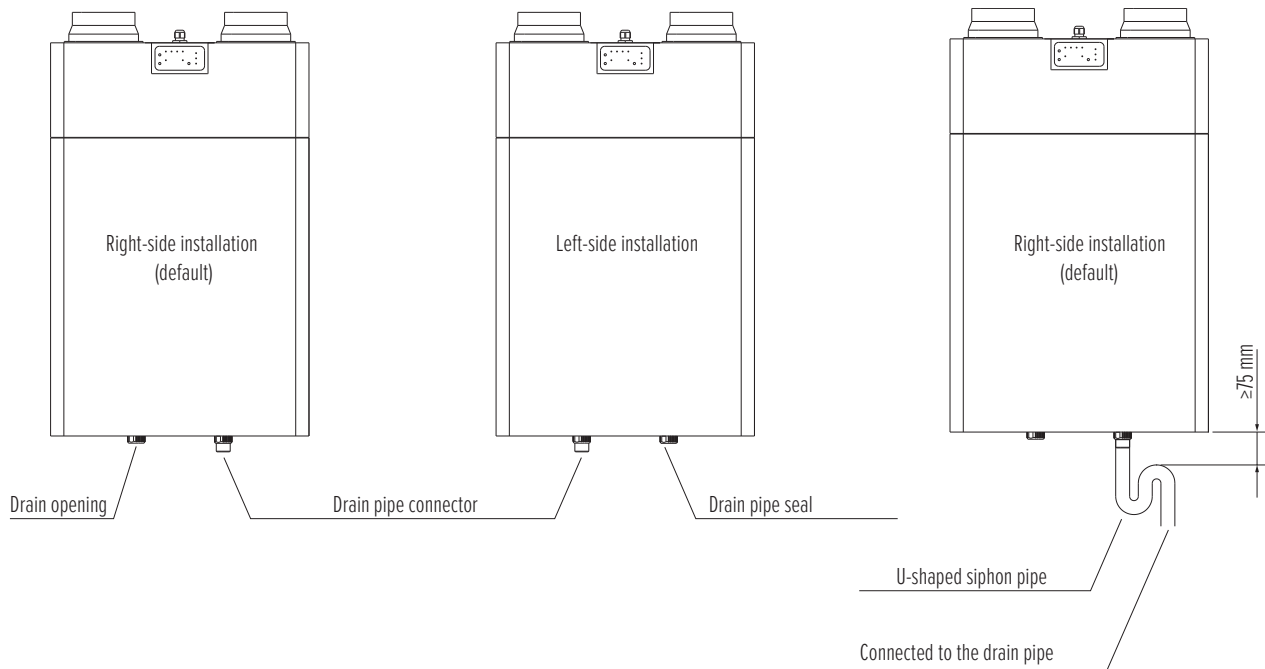

- Connect the drain pipe to the drain pipe connector using a U-shaped siphon pipe.
- Before using the unit, ensure the drain pipe is submerged into the water.
- Ensure all the connectors are tight and do not leak.

IV. PRE-START SETTINGS

4.1. INSPECTION BEFORE OPERATION

Carefully check the following:

- Check the power supply voltage and frequency, and make sure the unit is properly connected to the power source.
- The unit must be properly connected to the ground.
- The air ducts and the condensate drain pipe must be properly connected to the unit.

4.2. DEFAULT FACTORY SETTINGS

The unit comes with the following default settings:

Model		MCFA250T	MCFA350T	MCFA500T
Flow rate, m ³ /h	Speed 1	80	100	105
	Speed 2	100	130	185
	Speed 3	145	180	270
	Speed 4	175	245	350

4.3. CONTROL PANELS

The unit has two control panels: the main panel for everyday settings and the auxiliary panel for advanced parameter settings. The panels are located as follows:

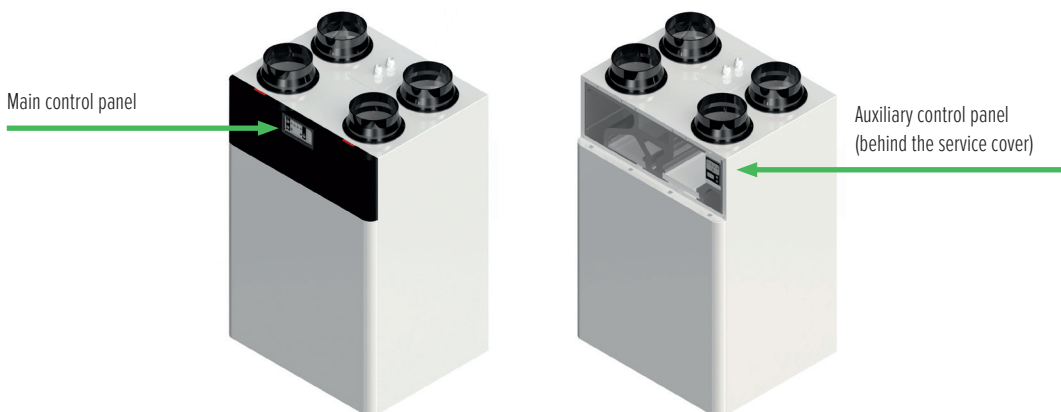

Main control panel

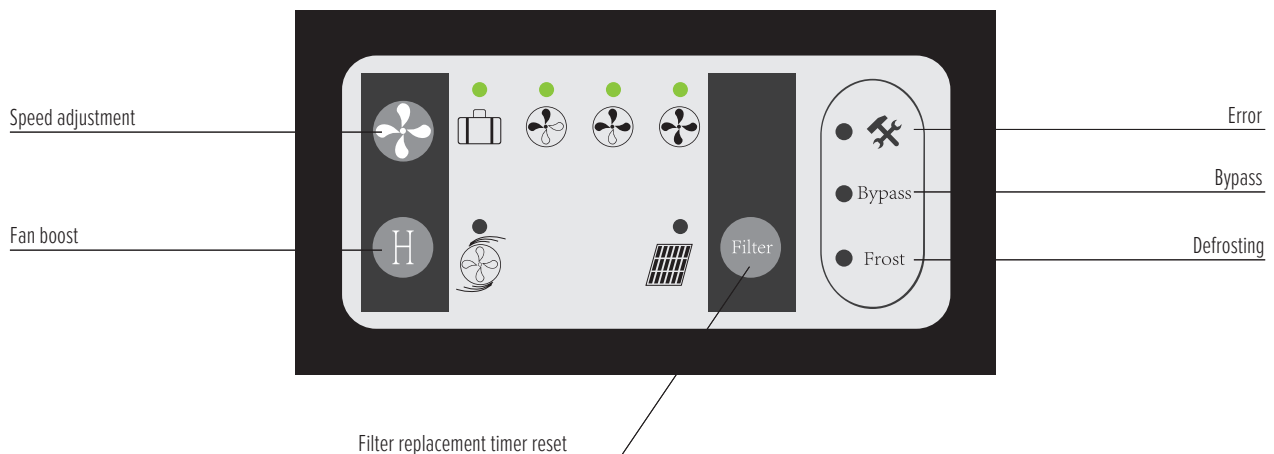

Speed adjustment: Press this button to switch between the speeds (from 1 to 4). Speed 1 is an “idle mode”, in which the fan operates at a very low speed.

Fan boost: When you press this button, the fan switches to the boost mode with increased rotation speed for 30 minutes, and then returns to the initial mode.

Filter replacement timer reset: The corresponding light goes up after 60 days of operation or when the filters require cleaning or replacement. After the filter has been cleaned or replaced, press and hold this button to reset the filter replacement timer.

Error indicator: When this light is on, this indicates an error in the fan or sensors. Once the error is reset, the indicator light goes off.

Bypass: This light is on when the bypass mode is enabled. When the bypass mode is disabled, the light goes off. Bypass opening temperature: 17 °C to 21 °C outdoors.

Humidity control: If relative humidity in the room exceeds 75% during the fan operation, the fan switches to the boost mode to operate at an increased speed until the relative humidity drops below 75%.

CO2 control (option): If a CO2 sensor is connected to the fan, and CO2 content in the room exceeds 1500 ppm during the fan operation, the fan switches to the boost mode to operate at an increased speed until the CO2 content drops below 1500 ppm.

Defrosting: This light is on when the defrosting mode is enabled. The defrosting mode is enabled when outdoor temperature is -5 °C or lower.

Note. The heat recovery unit cannot be controlled in the defrosting mode. Instead, it is controlled automatically so as to prevent freezing inside of the unit.

The above values are defaults. The default values can be changed using the auxiliary controller or via Modbus.

Auxiliary control panel

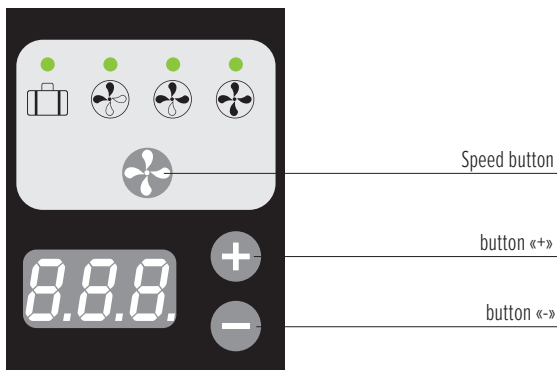

Air flow rate setting Press Speed to select a speed level from 1 to 4, and then press + or - to set the air flow rate for the selected speed. After you have set all the 4 speeds, press Speed again to save the settings. If you do not save the settings, they will be saved automatically in 15 seconds if there are no operations with the unit.

Balancing rate setting: Press and hold Speed for 6 seconds. Once the digital screen displays “LPL”, press + or - to set the supply and exhaust air balancing rate.

1. If the value is set to 0, the supply air flow rate will be equal to the exhaust air flow rate.
2. If the value is set between 1 and 50, the supply air flow rate will be higher than the exhaust air flow rate.
Note: The higher the value, the smaller the exhaust air volume.
3. If the value is set between -50 and -1, the supply air flow rate will be lower than the exhaust air flow rate.
Note: The higher the absolute value, the smaller the supply air volume.

Switching between right-side and left-side installation: Press and hold + for 6 seconds. Once the digital screen displays “PLP”, press Speed to switch between right-side and left-side installation. “1” is for right-side installation, and “2” is for left-side installation.

Note: The setting must correspond to the actual installation type, otherwise the heat recovery unit will not operate properly.

Restoring factory settings: Press + and - simultaneously to restore the air flow rate and the air flow balancing rate to the default factory settings.

RS-485 interface settings: Press and hold - for 6 seconds, and then press + or - to set the RS-485 interface address of the heat recovery unit for centralized control.

Note: Request the Modbus specification from the supplier / manufacturer if necessary.

V. TROUBLESHOOTING





If you notice any malfunctions of the unit, inspect the unit referring to the following table, and contact your supplier to resolve the issue promptly.

Phenomenon	Possible reasons	Solution
Insufficient fresh air supply	<ul style="list-style-type: none"> ■ Air inlet/outlet is obstructed. ■ The filters are clogged with dust 	<ul style="list-style-type: none"> ■ Inspect the units and remove the foreign objects. ■ Replace the filters.
Dripping sound	<ul style="list-style-type: none"> ■ The condensate drain pipeline is obstructed. 	<ul style="list-style-type: none"> ■ Clear the pipeline.
Operation noise	<ul style="list-style-type: none"> ■ The pipeline connected to the unit is loose. ■ Foreign objects have entered the unit. ■ The supply or exhaust fan is faulty 	<ul style="list-style-type: none"> ■ Disassemble the unit, clean it on the inside or replace the parts.
The unit fails to start	<ul style="list-style-type: none"> ■ Power wiring error. ■ The protective circuit breaker of the unit has tripped. 	<ul style="list-style-type: none"> ■ Check the wiring. ■ Close the protective circuit breaker.

In case of any other malfunctions contact the service centre.

VI. ACCESSORIES

You can optionally install the following accessories and configure them according to your needs. The accessories must be purchased separately.

N°	Image	Description
1		F7 filter
2		Touch-screen control panel
3		CO2 sensor with a wire of about 5 m long
4		Duct-type heater

