



INSTALLATION MANUAL

Energy-saving supply
and exhaust unit



MVS700-DW
MVS900-DW
MVS1100-DW
MVS1400-DW
MVS1600-DW
MVS2200-DW

CONTENTS

GENERAL DATA	3
SAFETY REQUIREMENTS	4
SPECIFICATIONS	5
OUTLINE DRAWINGS	6
INSTALLATION GUIDELINES	8
ELECTRICAL INSTALLATION	11
WIRING DIAGRAMS	12
SAFETY PRECAUTIONS	14
SMART TOUCH-SCREEN CONTROLLER	15
MAINTENANCE	24

GENERAL DATA

NECESSARY TOOLS

1. Hammer drill - for making holes in building structures for a pin and a brass dowel
2. Wrench set - for tightening nuts when hanging equipment on studs
3. Screwdriver set - to access the control board
4. Lifter - for lifting the equipment to a given height
5. Ladder - for the access of the installer to the equipment installed at a height
6. Current clamps - for voltage and current measurements during equipment start-up

ABOUT EQUIPMENT

The supply and exhaust unit with recuperation ensures the supply of fresh air to the room and the removal of stale air from it. Thanks to recuperation, the supply air is heated from the exhaust air without mixing the flows. Adjustment of the operating parameters of the supply and exhaust system is carried out thanks to the control panel.

Supply and exhaust units MVS***-DW are intended for horizontal installation indoors together with a system of air ducts and ventilation channels.

SAFETY PRECAUTIONS



Please read the following safety instructions before using the equipment. The supply and exhaust unit must be installed correctly by a specialized installation company.

Follow the safety instructions to avoid personal injury or damage to equipment or property. Please read the safety instructions below before installing the equipment, and make sure the unit is properly installed.

The symbols shown below indicate the potential degree of danger.









	Warns about possible property damage, serious injury or even death in case of failure to observe the requirements.
---	--

The symbols shown below indicate safety regulations that must be followed















	Warns about forbidden actions		Warns about necessary actions
---	-------------------------------	---	-------------------------------

SAFETY REQUIREMENTS

WARNING!

	The installation shall only be done by a qualified worker. The users shall not install or relocate the equipment on their own.		The outdoor air vents must be covered with a bird net or similar means. Make sure that there are no obstructions.
	The installer must strictly follow the instructions given in this manual. Failure to follow the instructions poses a health risk and may impair the unit performance.		The equipment shall be installed at a sufficient distance from a flue duct or any other dangerous fume sources.
	The unit must be installed in compliance with all the instructions specified in the manual, and mounted on a supporting structure that is able to withstand the unit weight.		The electric mains must be designed in compliance with local regulations. Use dedicated cables, as the use of smaller cables may lead to electric shock and fire.
	Power the unit off before maintenance or repair to avoid electric shock.		Never connect the grounding wire to a gas pipe, water supply pipe, lightning rod, or telephone line. Incorrect grounding may result in electric shock.

CAUTION!

	The power cable and wires must be installed by a qualified electrician. Improper connection may lead to overheating, fire, and decrease of efficiency.		Wrap the air ducts with heat insulation to avoid condensation. Whether or not other pipelines require heat insulation depends on the dew point conditions.
	If the pipeline passes through metal wall sheeting, provide insulation between the metal pipeline and the wall passage to avoid the risk of electric shock or current leakage.		The cover of the junction box shall be pressed down and closed to prevent ingress of dust and dirt. Excessive dust and dirt may lead to terminal overheating, fire or electric shock.
	Use proper fixtures and accessories, otherwise there will be a risk of fire, electric shock or equipment failure.		When using the equipment at height in a hot humid climate, ensure sufficient ventilation.
	The outdoor pipelines must be installed with the inlet down to avoid ingress of rain water. Incorrect installation may result in water leakage.		To prevent electric shock and fire, equip the installation with an appropriately sized MCB and an earth leakage circuit breaker.
	Do not install the equipment in a very humid environment, as this may lead to electric shock and fire.		Do not connect the equipment to a kitchen hood, as grease deposits may block the heat exchanger and the filter, as well as present a danger of fire.
	Do not install the equipment in places where poisonous or pungent gases are present.		Do not install the equipment near open flames to avoid overheating and fire.
	Avoid acidic and alkaline environments, as they pose the risk of poisoning or fire.		Maintain the rated level of supply voltage, as improper voltage may result in fire.

SPECIFICATIONS

Model		MVS 700-DW	MVS 900-DW	MVS 1100-DW	MVS 1400-DW	MVS 1600-DW	MVS 2200-DW	MVS 2800-DW	
Air flow rate (m ³ /h)		600	800	1000	1300	1500	2000	2600	
Air flow rate (l/s)		167	222	278	360	417	555	722	
External pressure (Pa)		97	100	86	90	72	77	81	
Enthalpy efficiency (%)	Cooling	59-74	55-66	58-70	56-68	63-71	60-68	56-68	
	Heating	61-78	57-76	62-75	59-70	65-73	62-72	59-70	
Heat transfer efficiency (%)		70-83	68-83	70-83	70-83	76-80	76-82	70-83	
Noise level, dB(A)		39	41	42	43	50	51.5	53	
Voltage (V)		220-240V / 1 phase / 50 Hz							
Input power (W)		162	290	327	424	700	724	848	
Power cable		3x1.5 mm ²	3x1.5 mm ²	3x1.5 mm ²	3x1.5 mm ²	3x1.5 mm ²	3x1.5 mm ²	3x1.5 mm ²	
Control cable		2x0.5mm ²	2x0.5mm ²	2x0.5mm ²	2x0.5mm ²	2x0.5mm ²	2x0.5mm ²	2x0.5mm ²	
Control	Standard	Yes (7-day clock)							
	(BMS)Modbus	Yes							
Fan type		BLDC fan motor							
Fan speed (supply)		10-speed fan control							
Fan speed (exhaust)		10-speed fan control							
Summer bypass		Yes (automatic, with an adjustable range)							
Defrosting		Yes (automatic, with an adjustable range)							
CO ₂ control		Additional sensor (on/off control within an adjustable range)							
Fan Boost contacts		Yes	Yes	Yes	Yes	Yes	Yes	Yes	
Fire shutdown		Yes	Yes	Yes	Yes	Yes	Yes	Yes	
Weight (kg)		34	53	61	71	106	122	142	
Dimensions: LxWxH (mm)		867×902×280	1134×884×388	1134×1134×388	1193×1243×388	1134×884×776	1134×1134×776	1193×1243×776	
Diameter (mm)		Ø200	Ø250	Ø250	Ø250	650×280	650×280	650×280	

OUTLINE DRAWINGS

MVS700-DW – MVS1100-DW

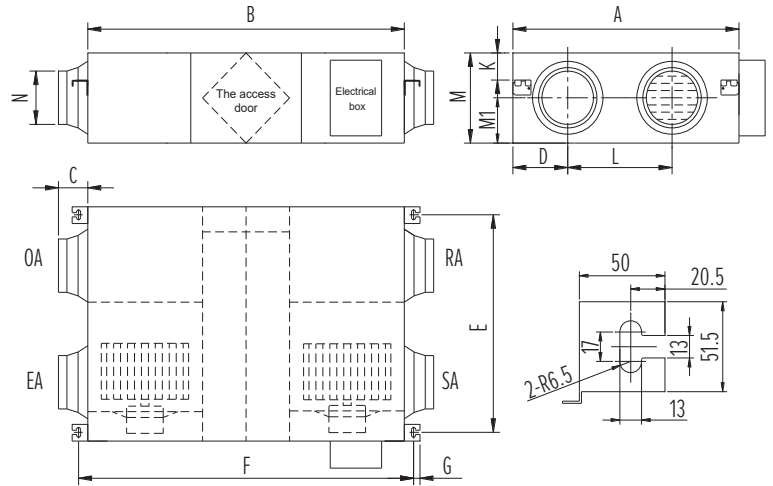

Legend:

EA – exhaust air
 OA – outdoor air
 SA – supply air
 RA – return air

Model	A	B	C	D	E	F	G	L	K	M	M1	N
MVS700-DW	902	867	107	197	833.5	922	20.5	451.5	115.5	280	139.5	ø194
MVS900-DW	884	1134	85	202	818	1189	20.5	378	128	388	194	ø242
MVS1100-DW	1134	1134	85	202	1068	1189	20.5	628	128	388	194	ø242

MVS1400-DW

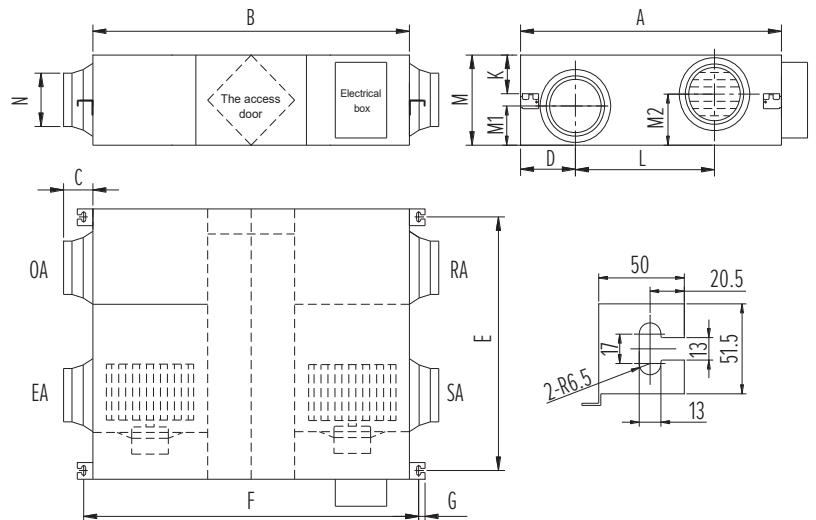

Legend:

EA – exhaust air
 OA – outdoor air
 SA – supply air
 RA – return air

Model	A	B	C	D	E	F	G	L	K	M	M1	M2	N
MVS1400-DW	1243	1193	85	241	1172.5	1248	20.5	629.5	133	388	191	241	ø242

OUTLINE DRAWINGS

MVS1600-DW – MVS2800-DW

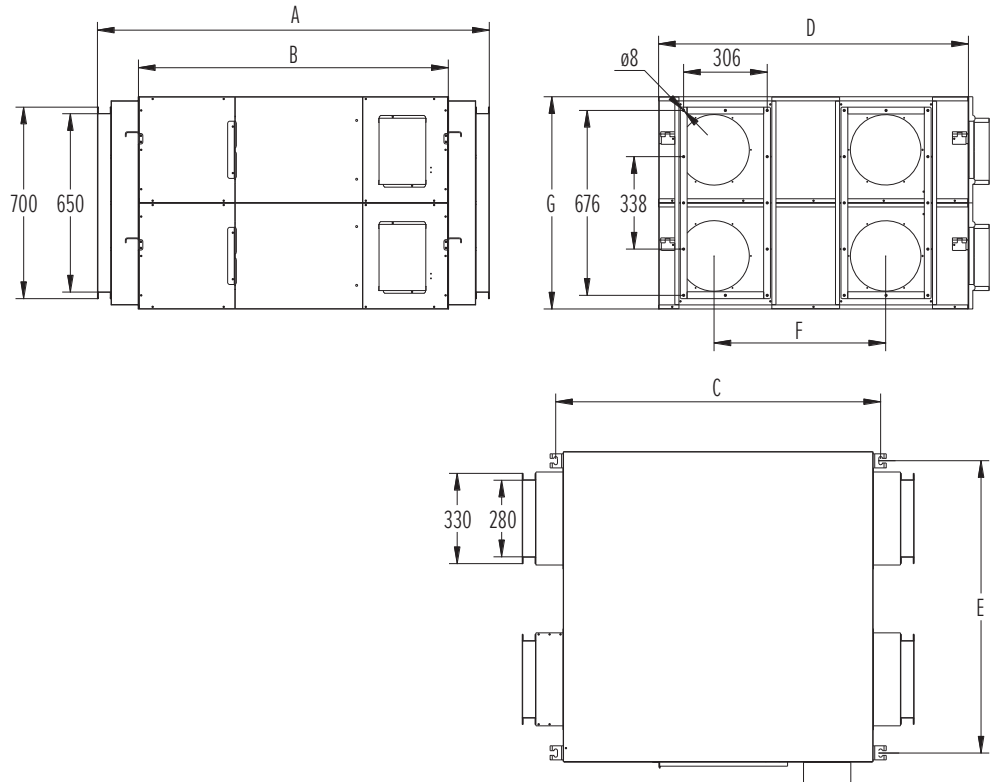

Legend:

EA – exhaust air
 OA – outdoor air
 SA – supply air
 RA – return air

Model	A	B	C	D	E	F	G	H	I
MVS1600-DW	1434	1134	1189	884	818	378	776	650	280
MVS2200-DW	1434	1134	1189	1134	1068	628	776	650	280
MVS2800-DW	1493	1193	1248	1243	1173	629.5	776	650	280

INSTALLATION GUIDELINES

Supply and exhaust units MVS***-DW are intended for horizontal installation indoors together with a system of air ducts and ventilation channels.

In the case of location behind a suspended ceiling, it is necessary to provide service doors to ensure access for

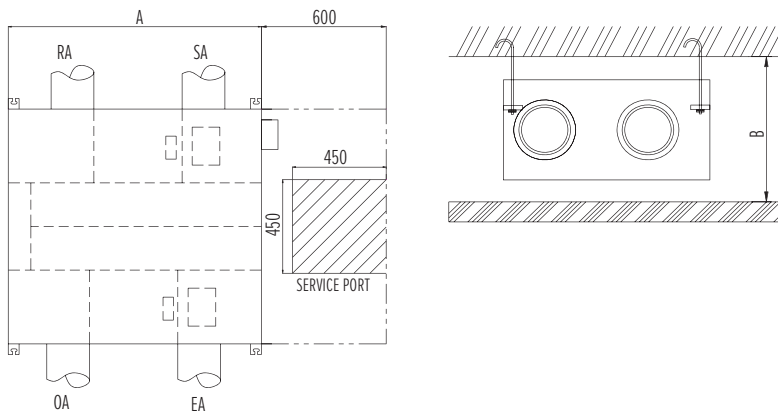

Model	A, mm	Indoor ceiling height B, mm
MVS700-DW	902	330
MVS900-DW	884	450
MVS1100-DW	1134	450
MVS1400-DW	1243	450
MVS1600-DW	884	450
MVS2200-DW	1134	450
MVS2800-DW	1193	450

1. Ensure that the ceiling height is not less than specified in column B of the table below.
2. Do not install the equipment next to the boiler fire tube.
3. When laying the pipeline, avoid the following:

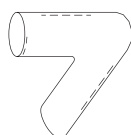

Bends

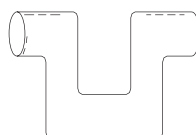

Multiple turns



Multiple pipeline reducers /
corrugated pipeline

INSTALLATION GUIDELINES

4. Do not use flexible pipelines.
5. Fire dampers must be installed according to local regulations and fire safety rules.
6. The equipment shall not be exposed to ambient temperatures over 40 °C or installed near open flames.
7. Take precautions to prevent formation of dew and frost. As shown on the diagram on the right, dew and frost will form on the unit, when the saturation curve runs through points A and C. Use a preheater to prevent formation of condensate and frost, while observing the conditions of the curve passing through points B and B' or through points C and C'.
8. The distance between two air vents on the outdoor side of the wall shall exceed 1000 mm to prevent the exhaust air from circulating back into the indoor unit.
9. If the unit includes a preheater, synchronize the unit operation with the preheater, since the preheater will start operating only after the unit starts.
10. The user can install a noise damper to minimize noise from the indoor unit.

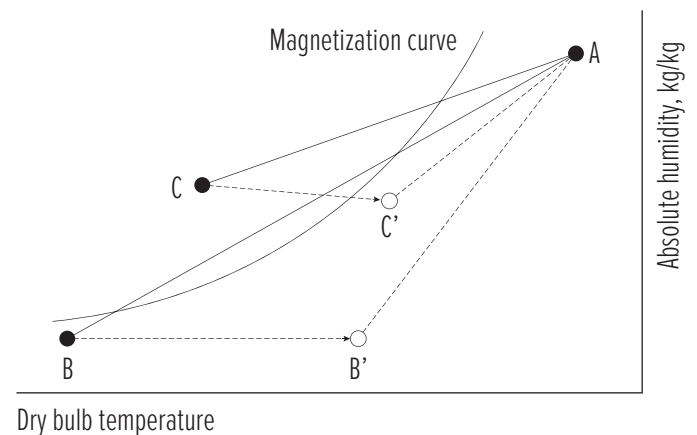

PHYSICAL INSTALLATION

1. Before installation, prepare the threaded joint with adjustable nuts and gaskets.
2. Install the equipment as shown on the above figure. The equipment must be fixed firmly and evenly.
3. Incorrect installation may lead to injury, equipment damage and excessive vibration. Uneven installation may affect the damper operation.
4. The unit is labelled in the reverse order.

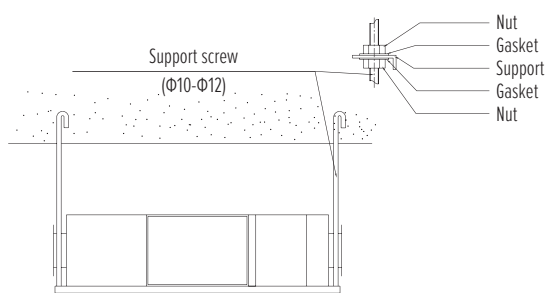

INSTALLATION GUIDELINES

AIR DUCT DESIGNING

1. Joints between the unit air vents and air ducts must be covered and sealed to prevent air leakage. When performing installation, always observe the applicable directives and rules.
2. The two outdoor air vents shall be sloped down in the outside direction to avoid ingress of rain water (at an angle of $1/100 - 1/50$).
3. Apply heat insulation to outside surface of both pipelines to prevent condensation. Material: glass wool, thickness: 25 mm.

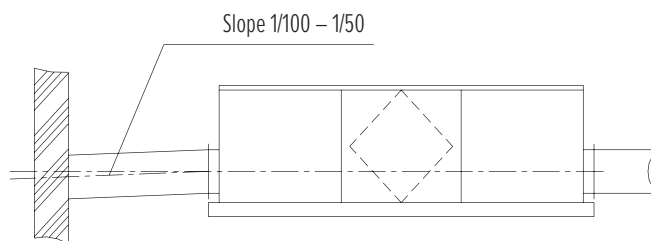

INSTALLATION DIAGRAM

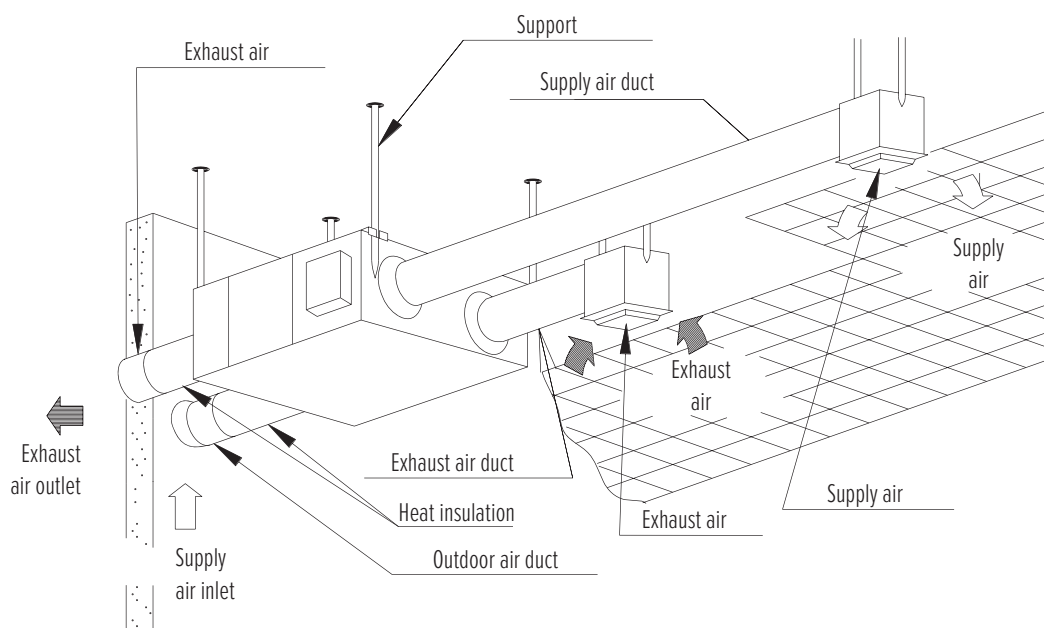

ELECTRICAL INSTALLATION

WARNING!

Disconnect the equipment from power supply before installation or maintenance to avoid electric shock. Specifications of the cables shall strictly meet the effective requirements. Failure to comply with the requirements may lead to malfunction or pose a danger of electric shock and fire.

The unit is powered with alternating current: 220 V AC / 50 Hz / 1 phase. Open the cover of the junction box, connect 2 cables (L/N/GND) to the terminals, and connect the cable of the control panel to the board according to the electrical installation diagram. Then, connect the cable to the control panel.

Model	Specifications of the power cable	Specifications of the controller cable
MVS700-DW to MVS2800-DW	3x1.5 mm ²	2x0.5 mm ²

WIRING DIAGRAMS

MVS700-DW – MVS1400-DW

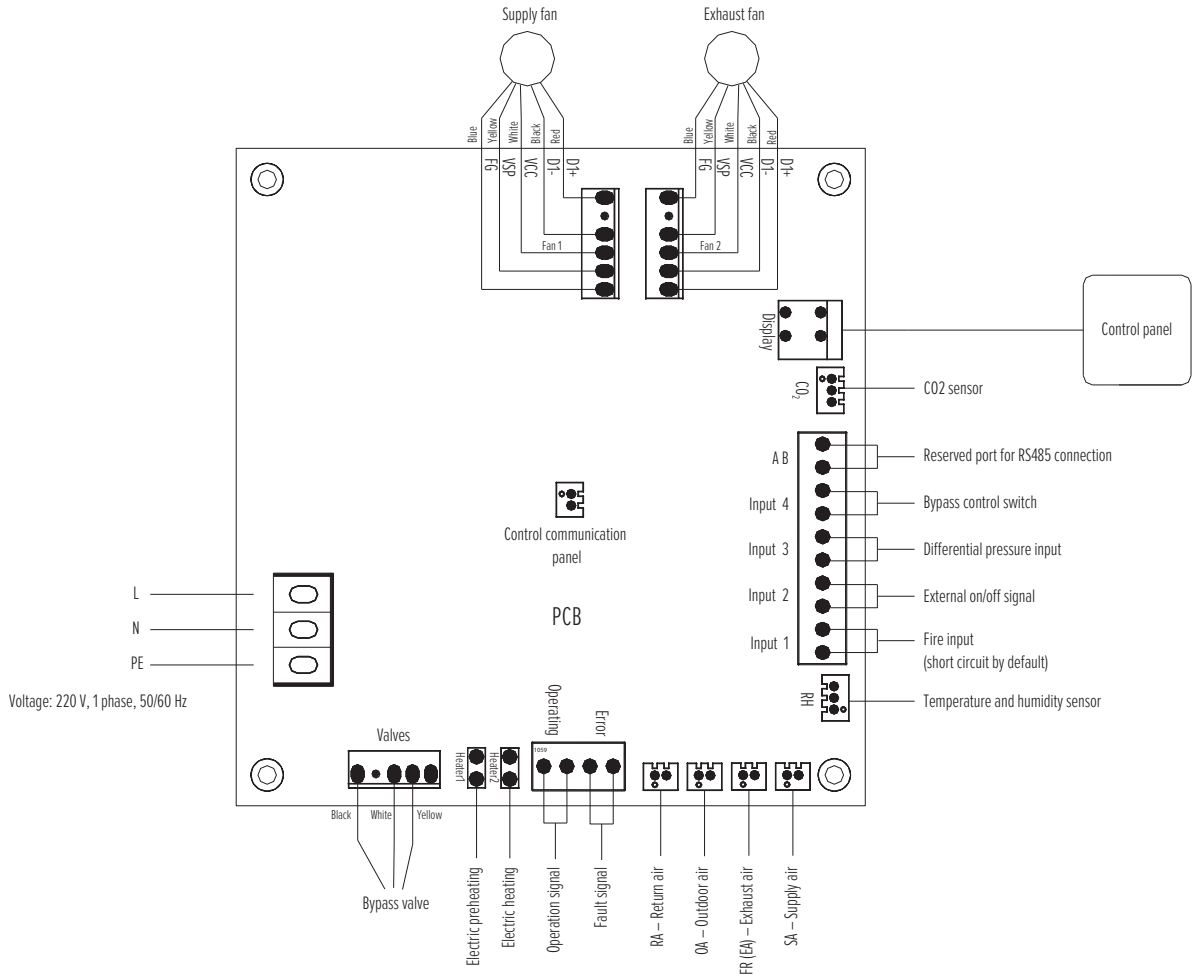

Model	Power supply	Panel type
MVS700-DW to MVS1400-DW	220 V AC, 50 Hz	HDK-CK-DC

WIRING DIAGRAMS

MVS1600-DW – MVS2800-DW

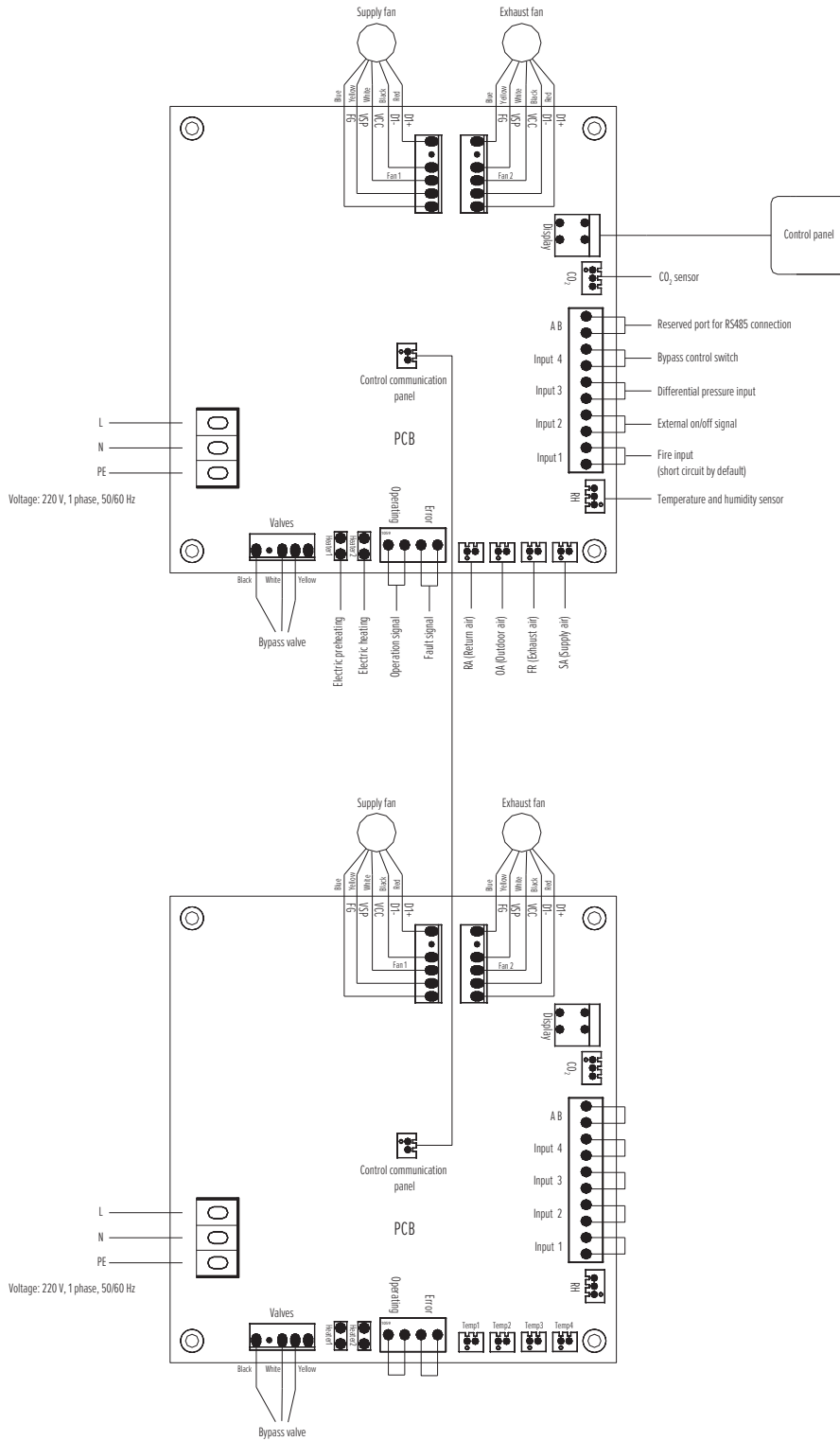







Model	Power supply	Panel type
MVS1600-DW to MVS2800-DW	220 V AC, 50 Hz	HDK-CK-DC

SAFETY PRECAUTIONS





COMMISSIONING

1. Check electric wiring after installation.
2. Switch on the power supply and perform commissioning and operation according to the controller instructions. Check operating conditions of the supply fan, exhaust fan and bypass. When the fan bypass valve is operating, the motor will stop in 10 seconds or more.
3. If there are any abnormalities during commissioning, consider the connection incorrect. In order to avoid electric shock, immediately turn off the dedicated switch and re-connect the wire properly.

WARNING!

	Loose or incorrect wiring connection may lead to explosion or fire.		Do not insert fingers and foreign objects into the unit openings. Otherwise you can get injured by the rotating impeller.
	Never install, relocate or re-install the unit on your own.		Before cleaning the heat exchanger, switch off the power supply and the circuit breaker.
	Continuous operation under abnormal conditions may lead to malfunction, electric shock or fire.		Do not attempt to disassemble or repair the unit on your own, as this may lead to electric shock or fire.

CAUTION!

	Do not install the equipment in a hot or humid place, as this may lead to malfunction, current leakage or fire.		Keep burners away from the fresh air intake to avoid fire.
	Before cleaning the unit, or if the unit will not be used for a long time, disconnect the unit from power supply (otherwise there will be a risk of electric shock).		Observe directives and regulations relating to combustion appliances.
	Clean the filter regularly. Filter clogging may impair quality of air in the room.		

SMART TOUCH-SCREEN CONTROLLER

CONTROL PANEL

The smart controller in the form of an LCD touch screen is mounted on the outside.



DESCRIPTION OF THE CONTROL PANEL

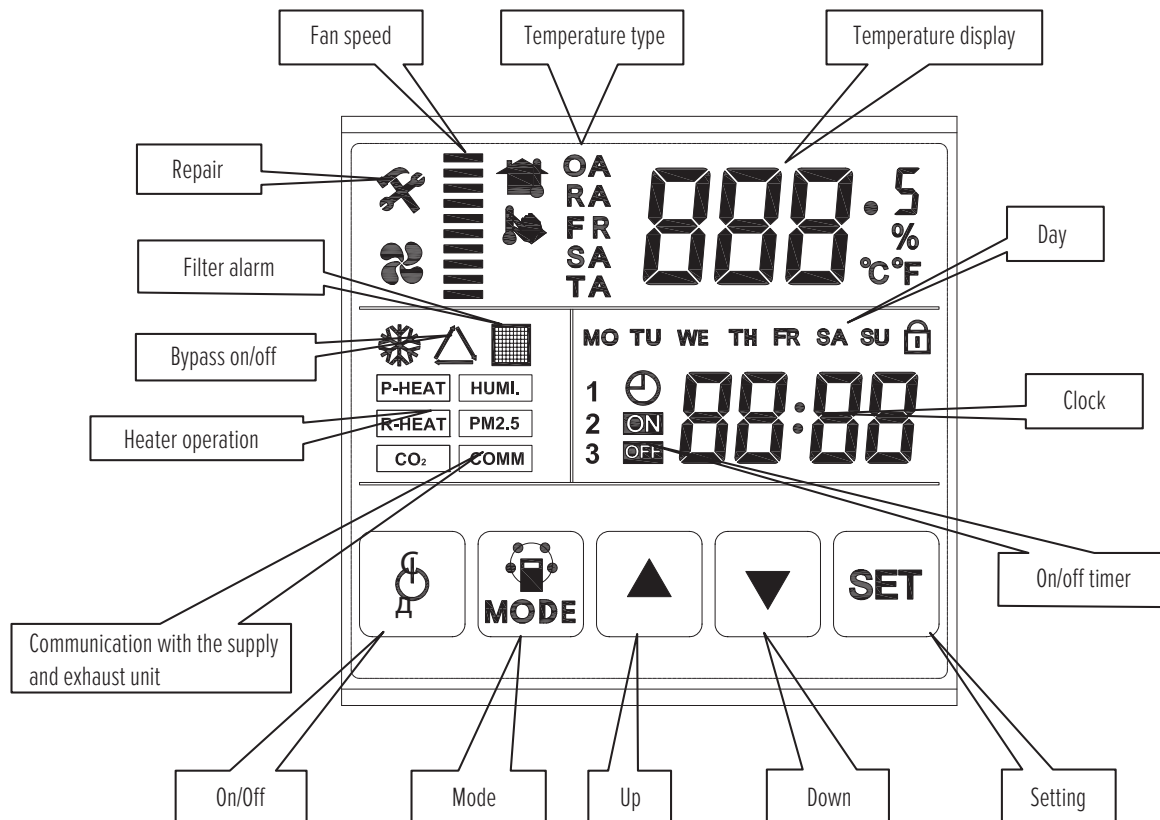

SMART TOUCH-SCREEN CONTROLLER

OPERATING INSTRUCTION

- On/Off:** Press On/Off once to switch the unit on, and press this key again to switch the unit off. Backlighting of the LCD screen goes on when the unit switches on, and goes off when the unit switches off. The backlighting will also go off, if there are no operations with the keypad for 30 seconds. Press and hold On/Off for 6 seconds to enable or disable the keypad lock.

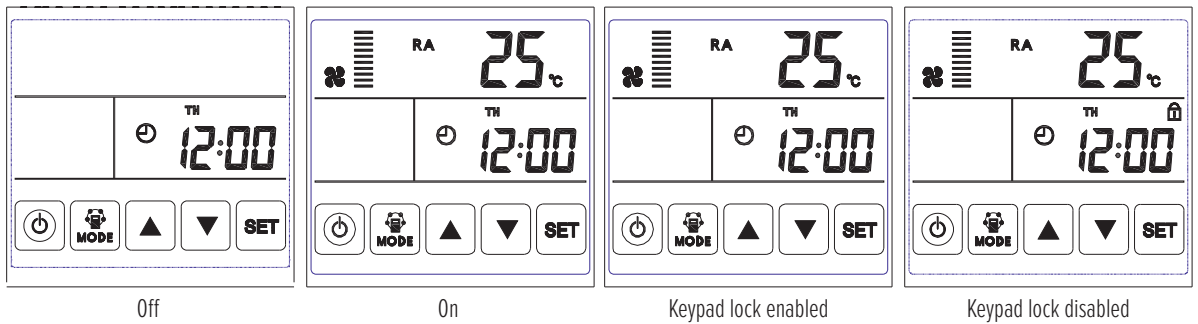

- Mode change:** Press MODE to display RA-OA-FR (EA)-SA modes (that is, return / outdoor / exhaust / supply air temperature settings), CO₂ content, or humidity control (if the sensors are connected).

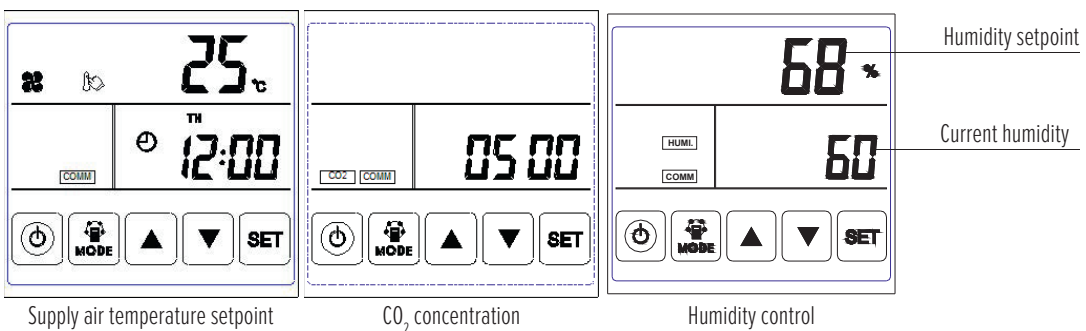
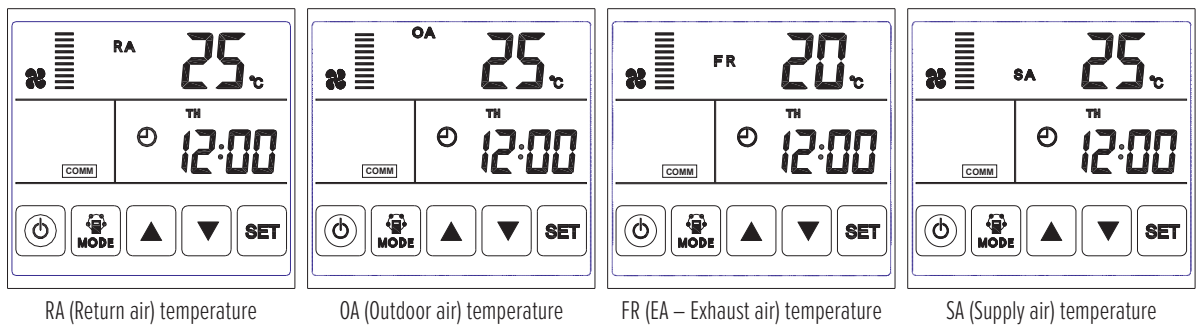

SMART TOUCH-SCREEN CONTROLLER

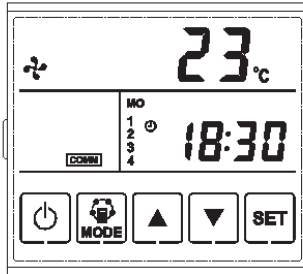

Mode on/off time

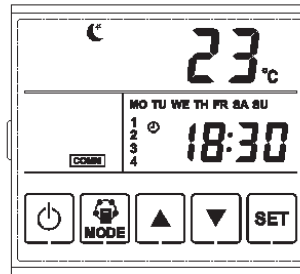

Sleep mode

3. Fan speed setting:

- A. Manual fan speed setting: press arrow keys ▲ and ▼ on the SA (supply air) or FR (EA – exhaust air) temperature display to set the fan speed. The exhaust fan speed can be set in the FR interface, while the supply fan speed can be set in the SA interface. There are 3 speeds in the AC controller, while the DC controller supports 10 speeds.
- B. Automatic fan speed setting: four-interval timer. You can set 4 intervals per day, 7 days per week, with an individual fan speed setting for each time interval. After that, when the fan enters the specified time interval, the fan speed automatically changes according to the settings.

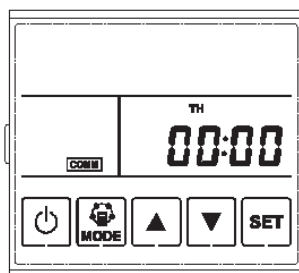

Time setting

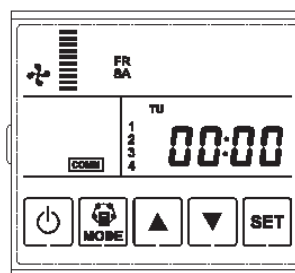

Timer setting

4. **Time setting:** Press and hold SET in the timer setting interface to enter the time setting. The time indicator will light up. Press Up and Down to set the Hours; once the hours are set, briefly press SET again to set the Minutes and Days of the Week; then press Mode or On/Off to exit the setting.

SMART TOUCH-SCREEN CONTROLLER

- 5. Timer setting:** Briefly press SET in the timer mode interface to enter the timer setting. Now, you will set the Day of the Week. For that purpose, press UP and DOWN to select Days of the Week. Briefly press SET to set Hours of the first interval, and press UP and DOWN to select the hours. Briefly press SET to set the Minutes, and press UP and DOWN to select the minutes. Briefly press SET to set the SA (supply air) fan speed, and press UP and DOWN to select the fan speed. Briefly press SET to set the EA (exhaust air) fan speed, and press UP and DOWN to select the fan speed.

Once you complete setting the first interval, settings of the second interval will change automatically. Once you complete setting all 4 intervals, the system will automatically go back to weekly setting. Repeat the setting as described above, and then press MODE or On/Off to exit the setting.

Note: if there are no operations for more than 10 seconds, the system will automatically exit the setting.

- 6. Bypass on/off setting:** Go to the list of parameters, where parameter No. 2 is used to switch between manual and automatic bypass functions. Value 0 = manual bypass, value 1 = automatic bypass
- Manual bypass on/off setting: to open the bypass, go to the OA temperature interface, and hold the arrow key ▲ for 6 seconds until the bypass icon lights up. To close the bypass, hold the arrow key ▼ for 6 seconds, until the bypass icon disappears.
 - To set the automatic bypass function, use parameters No. 3 and No. 4 in the list of parameters. The bypass is open, when the fresh air temperature is between X and $X + Y$. That is, if $X = 19$, $Y = 3$, the bypass will be open when the fresh air temperature is between 19 and 22 °C, and closed when the fresh air is cooler than 19 °C or hotter than 22 °C.

SMART TOUCH-SCREEN CONTROLLER

7. Temperature setting: Press arrow keys ▲ and ▼ in the temperature setting interface to adjust the set temperature between 15 and 30 °C. If the supply air temperature exceeds the set temperature, the electric heater will stop, while p-heat and r-heat icons will disappear. If the supply air temperature is equal to or below the set temperature (and the temperature difference is within 5 °C), the first-stage electric heater will start, and the p-heat icon will light up. If the supply air temperature is lower than the set temperature by more than 5 °C, the first- and second-stage electric heaters will start simultaneously, and both p-heat and r-heat icons will be displayed. Once the supply air temperature is 2 °C below the set temperature, the second-stage heater will stop, and if the supply air temperature exceeds the set temperature, both heater stages will stop. Please note that this function is only available when the electric heater is connected to the circuit board. To enable this function, set parameter No. 5 (heater function) to 1.

8. Parameter setting: Press MODE for more than 6 seconds to enter the parameter setting interface.

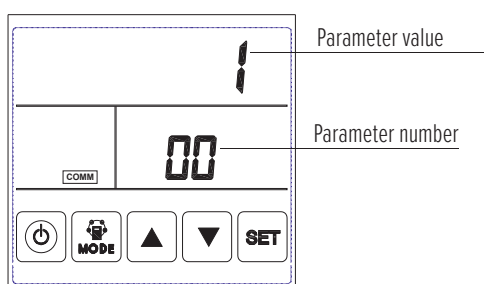

Then, increase the parameter number with a long press on the SET key. Once you select the required parameter number, press arrow keys ▲ and ▼ to adjust the parameter value. When all the settings are completed, press SET to go to the next step.

⚠ CAUTION!

1. After the parameters have been set, it will take about 15 seconds to record them in memory. During this time, the power supply shall remain on.
2. Please see the table of available parameters below to set the appropriate parameters for different demands.

SMART TOUCH-SCREEN CONTROLLER

CAUTION!

1. After the parameters have been set, it will take about 15 seconds to record them in memory. During this time, the power supply shall remain on.
2. For the list of available parameters, see the table below.

N°	Content	Range	Default	Unit of	Input position
1	Automatic restart	«no» - disabled,, «yes»-enabled	«yes»		Main control panel
2	Automatic bypass	0 - disabled, 1-enabled	0		Main control panel
3	Bypass opening temperature X	5-30	19	°C	Main control panel
4	Bypass opening temperature range Y	2-15	3	°C	Main control panel
5	Electric heating setting	0 = electric heating is off, 1 = electric heating is on	0		Main control panel
6	Normal defrosting	0 - disabled, 1-enabled	1		Main control panel
7	Defrosting interval	15-99	30	minutes	Main control panel
8	Inlet temperature defrosting	+5 [~] -9	- 1	°C	Main control panel
9	Defrosting duration	2-20	10	minutes	Main control panel
10	CO2 display (enabled / disabled)	0 - disabled, 1-enabled	0		
11	CO2 sensor function	CO ₂ concentration	1500	800-2000	
12	Humidity display	0 - disabled, 1-enabled	0		
13	Humidity sensor function	humidity setting	70	50-100	
14	MODBUS address	1-66	1		
15	Fan speed adjustment	1 - 3 speeds (AC) 2 - 10 speeds (BLDC)	1		
16	DC fan speed selection	0 = air flow rate 150 m3/h 1 = air flow rate 250 m3/h 2 = air flow rate 350 m3/h 3 = air flow rate 200 m3/h 4 = air flow rate 300 m3/h 5 = air flow rate 400 m3/h 6 = air flow rate 600 m3/h 7 = air flow rate 800/1500 m3/h 8 = air flow rate 1000/2000 m3/h 9 = air flow rate 1300/2600 m3/h	0		
17	Filter signal	0 - free 1 - filter cleaning alarm and reset time	0		
18	Filter signal setting	0:45 days 1:60 days 2:90 days 3: 180 days	0		
19	Differential pressure function	0 - disabled, 1-enabled	0		
20	Резервний				

SMART TOUCH-SCREEN CONTROLLER

- A. For the description of parameters 02, 03 and 04 (automatic bypass function), see parameters No. 3 and No. 4 in the list of parameters. The bypass is open, when the fresh air temperature is between X and X + Y, and closed if the fresh air temperature is below 19 °C or above 22 °C. That is, if you set X = 19, Y = 3, the bypass will be open when the fresh air temperature is between 19 and 22 °C, and the bypass will close when the fresh air becomes cooler than 19 °C or hotter than 22 °C.
- B. Description of parameters 06, 07, 08 and 09 (normal defrosting). Normal defrosting: when EA (exhaust air) temperature is below the set defrosting temperature (1 °C by default) for 1 minute, and the defrosting interval (30 minutes by default) has expired, the supply fan will stop, and the exhaust fan will operate at high speed, until the EA (exhaust air) temperature becomes +15 °C. The unit will operate in the defrosting mode for a certain time (that is, defrosting duration, which is 10 minutes by default), after which the fan will return to the initial mode.
- C. Description of parameters 10 and 11 (CO2 sensor function). When the fan operates in the standby mode or at any speed different from the highest one, and the CO2 sensor detects that CO2 concentration has been exceeding the set value for more than 5 seconds, the fan will automatically start running at high speed. The fan will only return to the initial mode, when CO2 concentration has been below the set value for more than 5 seconds.
- D. Description of parameters 12 and 13 (humidity sensor function). When the fan operates in the standby mode or at any speed different from the highest one, and the humidity sensor detects that humidity has been exceeding the set value for more than 50 seconds, the fan will automatically start running at high speed. The fan will only return to the initial mode, when humidity has been below the set value for more than 5 seconds.
- 9. Filter signal, parameter 18 (used to set the filter alarm time):** When the time of fan operation exceeds the set time, the filter icon will start flashing to warn the user that the filter must be cleaned. After cleaning the filter, reset the time by setting parameter 17 to 1.

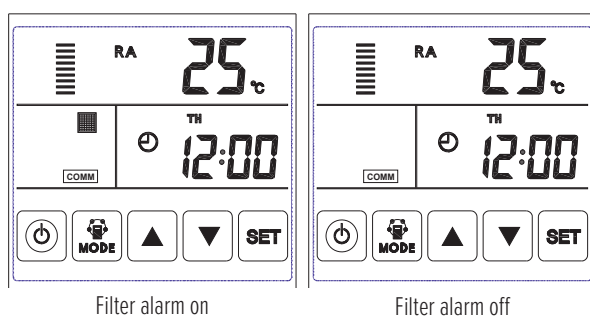

SMART TOUCH-SCREEN CONTROLLER

- 10. Reset to factory settings:** When the unit is on, simultaneously press arrow keys▲ and ▼ for more than 6 seconds to restore factory settings of the parameters. Once the factory settings are restored, the fan will turn off.
- 11. Checking the error code:** Briefly press SET in the main interface to check the fan error code using the table below. To exit the error display, press arrow keys▲ and ▼.

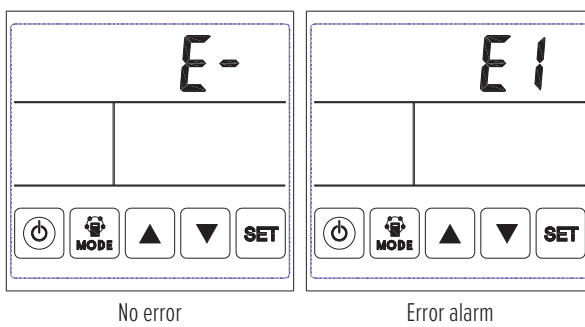

Code	Error
E1	OA temperature sensor error
E2	Memory error
E3	RA temperature sensor error
E4	EA temperature sensor error
E5	Communication error
E6	SA temperature sensor error
E7	Fire alarm error

MODBUS PROTOCOL

Baud rate: 9600 bps

Parity check: No

Data bits: 8

Stop bit: 1

Communication interval: > 200ms

Supported function code: 0x03, 0x06

Register address	Readable	Writeable	Value range	Function description	Remark
0(0x0000)	√	√	0-1	on-off state 0 - off, 1 - on	
1(0x0001)	√	√	1-10	Supply fan speed	
2(0x0002)	√	√	1-10	Exhaust fan speed	
3(0x0003)	√	√	15-30	Temperature setting	
4(0x0004)	√		0-100	Humidity, %	
5(0x0005)	√		0-2000	CO ₂ ppm	

SMART TOUCH-SCREEN CONTROLLER

Register address	Readable	Writeable	Value range	Function description	Remark
6(0x0006)	√		0-120	Fresh air temperature	Positive temperature: if the reading value is equal to or below 20, the actual temperature will be equal to the temperature reading minus 20. Negative temperature: if the reading value is below 20, the actual temperature will be equal to 20 minus the temperature reading.
7(0x0007)	√		0-120	Exhaust air temperature	
8(0x0008)	√		0-120	Supply air temperature	
9(0x0009)	√		0-120	Return air temperature	
10(0x000a)	√		0	--	
11(0x000b)	√		0-255	Fire alarm protection: bit 0 OA temperature sensor error: bit 1 EA temperature sensor error: bit 2 RA temperature sensor error: bit 3 SA temperature sensor error: bit 4 Humidity sensor error: bit 5 CO2 sensor error: bit 6 Filter alarm: bit 7	
12(0x000c)	√		0-1	Bypass switch, 1 = on, 0 = off	
13(0x000d)	√		0-1	p-heating state: 1 = on, 0 = off	
14	√		0-1	r-heating state: 1 = on, 0 = off	
15	√		0	0	
16	√		0	0	
17	√		0	0	
18	√		0	0	
19	√		0	0	
20	√		0	0	
21	√		0	0	
22	√	√	0-23	System time: hours	
23	√	√	0-59	System time: minutes	
24	√	√	1-7	System time: week	
25	√	√	1-99	IP address	

MAINTENANCE

TROUBLESHOOTING

Before contacting the manufacturer, you can try to eliminate the faults on your own, following the instructions in the table.

Fault	Possible reason	Solution
Air flow rate through the air vents has notably decreased with time	The filter is clogged with dust and dirt that obstruct air passage	Replace or clean the filter
Noise from the air vents	Air vent joints are loosened	Tighten the air vent joints
The unit does not operate	1. There is no power supply 2. The protective breaker is switched off	1. Check the power supply 2. Close the breaker

